

## OSHA Compliant Stair System



### OSHA Compliant Stairs Features:

- Adjustable From 25.5 to 34 inches in height
- Side Exit (right or left) or Straight across models
- 3-4 Steps
- Easy to Reconfigure
- Permanent (perforated) non-skid surface
- 4 independent and quick-adjusting legs for complete level-ability
- Made of durable, lightweight aluminum and galvanized steel that does not rust, rot or decay.
- Perfect solution for commercial applications including modular buildings
- Requires minimal assembly
- 3-year manufacturer's warranty!



**All our OSHA Steps are proudly Made in the USA!**

Fast, Free Shipping! 30 Day Return Policy

# OSHA Compliant Stair System

Universal design provides flexibility and standardization with a single supplier!

- Individual serial # for easy tracking of assets.
- Slip-resistant, self-draining reinforced deck and tread surface
- Welded in accordance with ANSI/AWS D1.1-D1.2-97 Structural Welding Code
- Step-in-stock GUARANTEE
- 100 lbs. per Square Foot Capacity
- Guard Rail Height 42"
- Handrail Height 36"
- Usable Height: 25.5" to 34"
- Platform Size: 40" W x 60" D
- Platform Leg Adjustment 10"
- Step Depth: 9.5"
- Riser Height 8.5"
- Step width: 36"

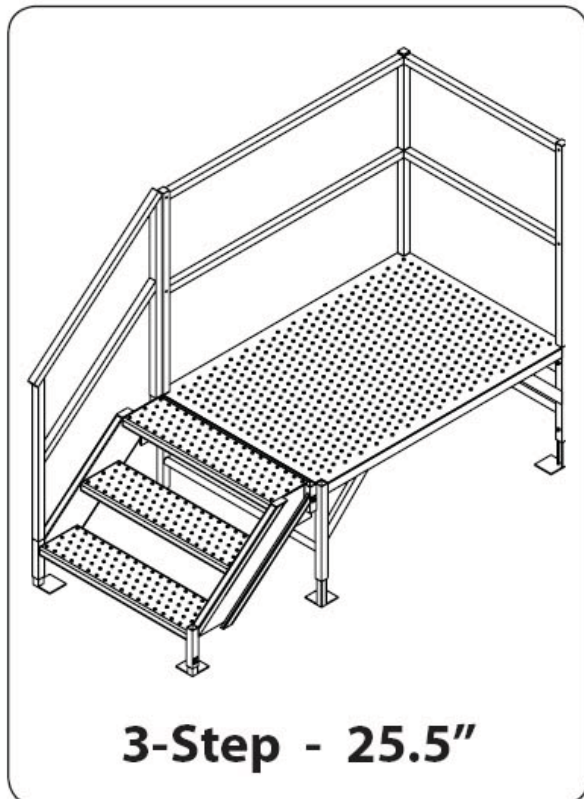
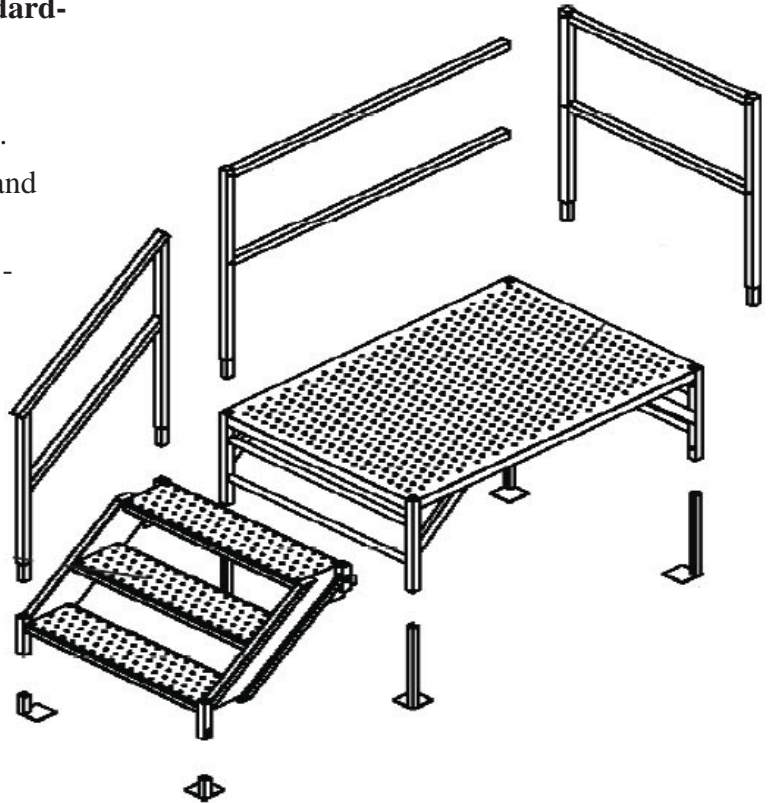

**3-Step - 25.5"**

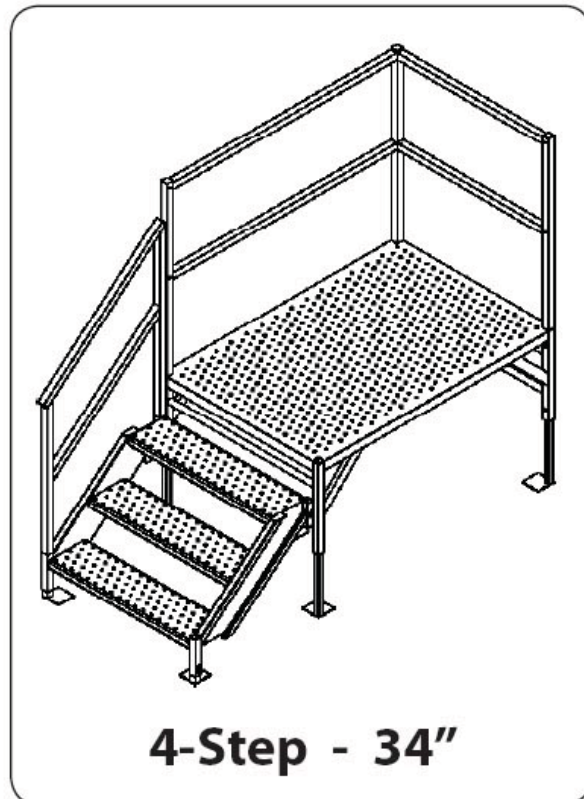

**4-Step - 34"**

Shown with optional riser legs